

## SPECIAL MOUNTING OPTIONS - 8MM UPRIGHT (1R, 2RL & 3RL)

Display Case Applications: 1R and 2RL fixtures can be combined with 8mm End-Mount, T-Mount or Corner Mount Upright Legs to create a highly-customized display fixture system.

● Options marked by orange dots are factory-installed and must be specified on product configurator.

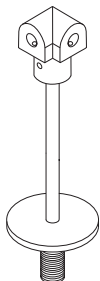

| 8MM END MOUNT LEG   |     | SPECIFICATIONS   | CAT. NO. | ELL - AC - | - EM8 -  |    |   |    |     |    |    |     |    |    |  |  |    |
|---|-----|--|----------|------------|--|----|---|----|-----|----|----|-----|----|----|--|--|----|
| 1R, 2RL   | 3RL | <p>Dimensions: 8mm leg ; 0.63" (15.88mm) diameter extrusion</p> <p>Material: Anodized Aluminum</p> <p>Weight: Variable</p> <p>Finish: Silver (AL), Black (BL), Bronze (BZ) Anodized; or White (WH) Powder Coated</p> |          |            | <table border="1"> <tr><td>1R</td><td>6</td><td>AL</td></tr> <tr><td>2RL</td><td>12</td><td>BL</td></tr> <tr><td>3RL</td><td>18</td><td>BZ</td></tr> <tr><td></td><td></td><td>WH</td></tr> </table> | 1R | 6 | AL | 2RL | 12 | BL | 3RL | 18 | BZ |  |  | WH |
| 1R  | 6   | AL   |          |            |  |    |   |    |     |    |    |     |    |    |  |  |    |
| 2RL   | 12  | BL   |          |            |  |    |   |    |     |    |    |     |    |    |  |  |    |
| 3RL   | 18  | BZ   |          |            |  |    |   |    |     |    |    |     |    |    |  |  |    |
|   |     | WH   |          |            |  |    |   |    |     |    |    |     |    |    |  |  |    |
| <p>● <b>Description:</b> End Mount Leg for 1R or 2RL round extrusion. Factory Installed – must be specified on product configurator. End Mount Leg includes Ø8mm upright, threaded bushing with hardware and cover plate. Legs are adjustable and field cuttable to achieve fixture height of 1" to 18" [25.4mm to 457.2mm]. Max recommended span between uprights is 48" [1279.2mm]. Silver (AL), Black (BL), Bronze (BZ) or White (WH) finish to match fixture. Cutout Ø 3/4" [19mm].</p>   |     |  |          |            |  |    |   |    |     |    |    |     |    |    |  |  |    |
| 8MM T-MOUNT LEG   |     | SPECIFICATIONS   | CAT. NO. | ELL - AC - | - TM8 -  |    |   |    |     |    |    |     |    |    |  |  |    |
| 1R, 2RL   | 3RL | <p>Dimensions: 8mm leg; 0.63" (15.88mm) diameter extrusion</p> <p>Material: Anodized Aluminum</p> <p>Weight: Variable</p> <p>Finish: Silver (AL), Black (BL), Bronze (BZ) Anodized; or White (WH) Powder Coated</p>  |          |            | <table border="1"> <tr><td>1R</td><td>6</td><td>AL</td></tr> <tr><td>2RL</td><td>12</td><td>BL</td></tr> <tr><td>3RL</td><td>18</td><td>BZ</td></tr> <tr><td></td><td></td><td>WH</td></tr> </table> | 1R | 6 | AL | 2RL | 12 | BL | 3RL | 18 | BZ |  |  | WH |
| 1R  | 6   | AL   |          |            |  |    |   |    |     |    |    |     |    |    |  |  |    |
| 2RL   | 12  | BL   |          |            |  |    |   |    |     |    |    |     |    |    |  |  |    |
| 3RL   | 18  | BZ   |          |            |  |    |   |    |     |    |    |     |    |    |  |  |    |
|   |     | WH   |          |            |  |    |   |    |     |    |    |     |    |    |  |  |    |
| <p>● <b>Description:</b> T-Mount Leg for connecting two 1R or 2RL round extrusions in a straight line. Multiple T-Mount Legs can be used to create extended display case fixturing. Factory Installed – must be specified on product configurator. T-Mount Leg includes Ø8mm upright, threaded bushing with hardware and cover plate. Legs are adjustable and field cuttable to achieve fixture height of 1" to 18" [25.4mm to 457.2mm]. Max recommended span between uprights is 48" [1279.2mm]. Silver (AL), Black (BL), Bronze (BZ) or White (WH) finish to match fixture. Cutout Ø 3/4" [19mm].</p>                               |     |  |          |            |  |    |   |    |     |    |    |     |    |    |  |  |    |
| 8MM CORNER MOUNT LEG  |     | SPECIFICATIONS   | CAT. NO. | ELL - AC - | - CM8 -  |    |   |    |     |    |    |     |    |    |  |  |    |
|   |     | <p>Dimensions: 8mm leg; 0.63" (15.88mm) diameter extrusion</p> <p>Material: Anodized Aluminum</p> <p>Weight: Variable</p> <p>Finish: Silver (AL), Black (BL), Bronze (BZ) Anodized; or White (WH) Powder Coated</p>  |          |            | <table border="1"> <tr><td>1R</td><td>6</td><td>AL</td></tr> <tr><td>2RL</td><td>12</td><td>BL</td></tr> <tr><td></td><td>18</td><td>BZ</td></tr> <tr><td></td><td></td><td>WH</td></tr> </table>    | 1R | 6 | AL | 2RL | 12 | BL |     | 18 | BZ |  |  | WH |
| 1R  | 6   | AL   |          |            |  |    |   |    |     |    |    |     |    |    |  |  |    |
| 2RL   | 12  | BL   |          |            |  |    |   |    |     |    |    |     |    |    |  |  |    |
|   | 18  | BZ   |          |            |  |    |   |    |     |    |    |     |    |    |  |  |    |
|   |     | WH   |          |            |  |    |   |    |     |    |    |     |    |    |  |  |    |
| <p>● <b>Description:</b> : Corner Mount Leg for connecting two 1R or 2RL round extrusions at a 90° angle. Multiple Corner Mount Legs can be used to create extended display case fixturing in unique shapes. Factory Installed – must be specified on product configurator. Corner Mount Leg includes Ø8mm upright, threaded bushing with hardware and cover plate. Legs are adjustable and field cuttable to achieve fixture height of 1" to 18" [25.4mm to 457.2mm]. Max recommended span between uprights is 48" [1279.2mm]. Silver (AL), Black (BL), Bronze (BZ) or White (WH) finish to match fixture. Cutout Ø 3/4" [19mm].</p> |     |  |          |            |  |    |   |    |     |    |    |     |    |    |  |  |    |



SPECIAL MOUNTING OPTIONS - 16MM UPRIGHT (2RL ONLY)

2RL fixtures can be combined with 16mm End-Mount, T-Mount or Corner Mount Upright Legs to create a highly-customized display fixture system. 16mm Upright Legs will provide a continuous .63" [15.9mm] leg to match the diameter of the 2RL fixture. 16mm Upright Legs can be composed of empty or illuminated segments. See diagrams and details on page 51 for more information. Contact factory for more information on specifying illuminated leg segments.

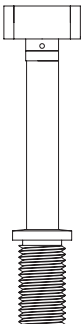
● Options marked by orange dots are factory-installed and must be specified on product configurator.

| 16MM END MOUNT LEG  | SPECIFICATIONS   | CAT. NO.   | ELL - AC - 2RL - EM16 - |    |  |
|---|--|--|-------------------------|----|--|
|    | <p>Dimensions: 0.63" (15.9mm) diameter extrusion leg</p> <p>Material: Anodized Aluminum</p> <p>Weight: Variable</p> <p>Finish: Silver (AL), Black (BL) Anodized; Bronze (BZ) or White (WH) Powder Coated</p> | <p>● <b>Description:</b> 16mm End Mount Leg/Connector for 2RL extrusion. Leg segments may be configured with empty or illuminated extrusion (Factory Installed – must be specified on product configurator. 16mm End Mount Leg includes 6", 12" or 18" upright and threaded bushing. Empty legs are adjustable and field cuttable to achieve fixture height of 1" to 18" [25.4mm to 457.2mm]. Illuminated legs are adjustable but NOT field cuttable. Max recommended span between uprights is 48" [1279.2mm] Silver (AL), Black (BL), Bronze (BZ) or White (WH) finish to match fixture. Cutout <math>\varnothing</math> 15/16" [24mm].</p>       | 6                       | AL |  |
|   |  |  | 12                      | BL |  |
|   |  |  | 18                      | BZ |  |
|   |  |  |                         | WH |  |
| 16MM T-MOUNT LEG  | SPECIFICATIONS   | CAT. NO.   | ELL - AC - 2RL - TM16 - |    |  |
|  | <p>Dimensions: 0.63" (15.9mm) diameter extrusion</p> <p>Material: Anodized Aluminum</p> <p>Weight: Variable</p> <p>Finish: Silver (AL), Black (BL) Anodized; Bronze (BZ) or White (WH) Powder Coated</p>     | <p>● <b>Description:</b> 16mm T Mount Leg/Connector for 2RL extrusion. Leg segments may be configured with empty or illuminated extrusion (Factory Installed – must be specified on product configurator. 16mm T Mount Leg includes 6", 12" or 18" upright and threaded bushing. Empty legs are adjustable and field cuttable to achieve fixture height of 1" to 18" [25.4mm to 457.2mm]. Illuminated legs are adjustable but NOT field cuttable. Max recommended span between uprights is 48" [1279.2mm] Silver (AL), Black (BL), Bronze (BZ) or White (WH) finish to match fixture. Cutout <math>\varnothing</math> 15/16" [24mm].</p>           | 6                       | AL |  |
|   |  |  | 12                      | BL |  |
|   |  |  | 18                      | BZ |  |
|   |  |  |                         | WH |  |
| 16MM CORNER MOUNT LEG   | SPECIFICATIONS   | CAT. NO.   | ELL - AC - 2RL - CM16 - |    |  |
|  | <p>Dimensions: 0.63" (15.9mm) diameter extrusion</p> <p>Material: Anodized Aluminum</p> <p>Weight: Variable</p> <p>Finish: Silver (AL), Black (BL) Anodized; Bronze (BZ) or White (WH) Powder Coated</p>     | <p>● <b>Description:</b> 16mm Corner Mount Leg/Connector for 2RL extrusion. Leg segments may be configured with empty or illuminated extrusion (Factory Installed – must be specified on product configurator. 16mm Corner Mount Leg includes 6", 12" or 18" upright and threaded bushing. Empty legs are adjustable and field cuttable to achieve fixture height of 1" to 18" [25.4mm to 457.2mm]. Illuminated legs are adjustable but NOT field cuttable. Max recommended span between uprights is 48" [1279.2mm] Silver (AL), Black (BL), Bronze (BZ) or White (WH) finish to match fixture. Cutout <math>\varnothing</math> 15/16" [24mm].</p> | 6                       | AL |  |
|   |  |  | 12                      | BL |  |
|   |  |  | 18                      | BZ |  |
|   |  |  |                         | WH |  |

## SPECIAL MOUNTING OPTIONS - 8MM UPRIGHTS

(Fig. A) below details the dimensions to be considered when designing a basic two-legged fixture using 8mm Upright Legs. For more complex configurations that include T-Mount and Corner Mount Leg components (Fig. B) please visit the website and download the "8mm Free-Standing Display Worksheet" on the 1R or 2RL Downloads tab. Glass showcases can also be configured using a single leg support combined with Self-Adhesive Locking Clips (page 41) which adhere directly to the glass surface (Fig. C).

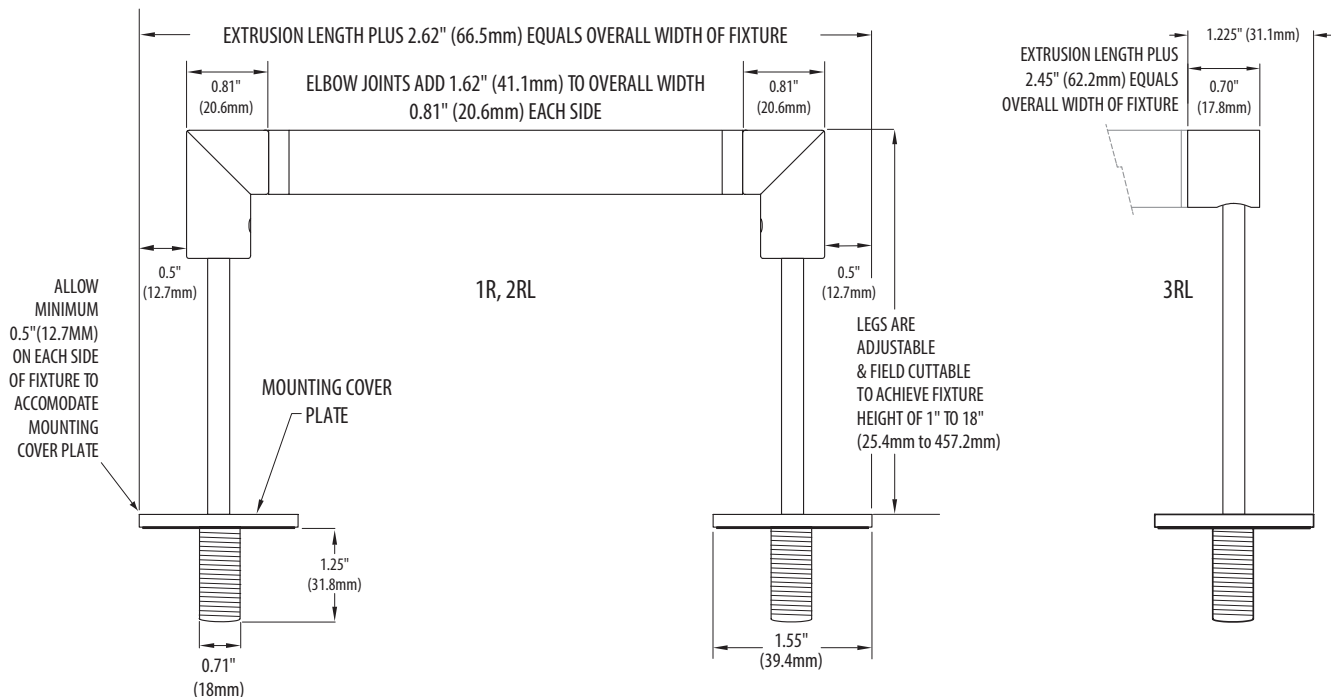

**Fig. B:** For laying out fixture configurations with three or more legs, please use the "8mm Free-Standing Display Worksheet" which can be found online on the 1R or 2RL Downloads tab.

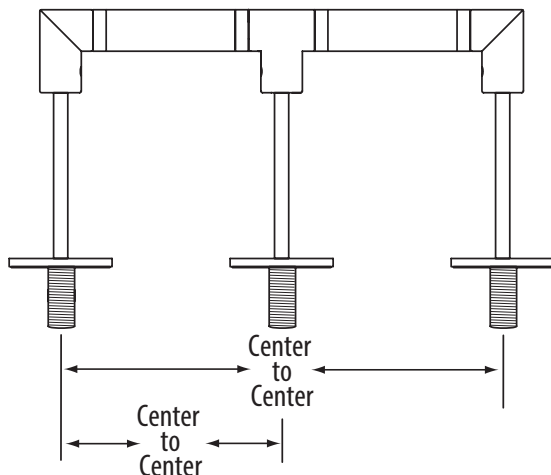

**Fig. C:** Single-legged configurations can be attached to glass surfaces using Self-Adhesive Locking Clip (pg. 41). One clip every 12"-16".

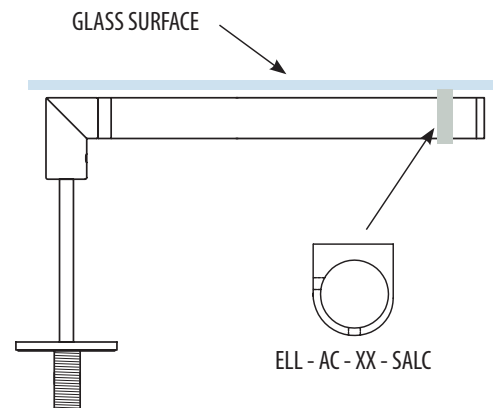

Cutout Dimension for 8mm Bushings

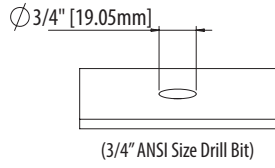

1. Installation with Underside Access:

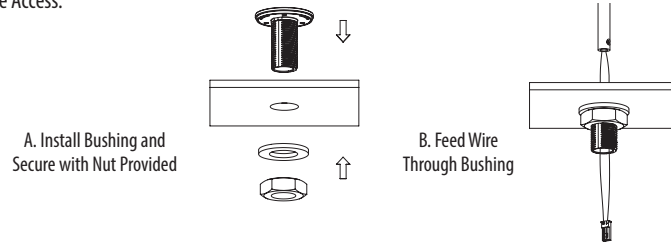

Height Adjustment

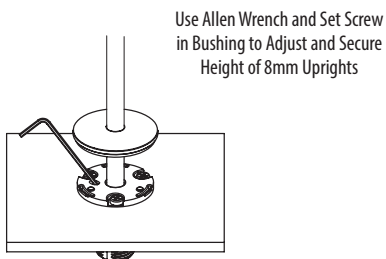

2. Installation with Topside Access Only

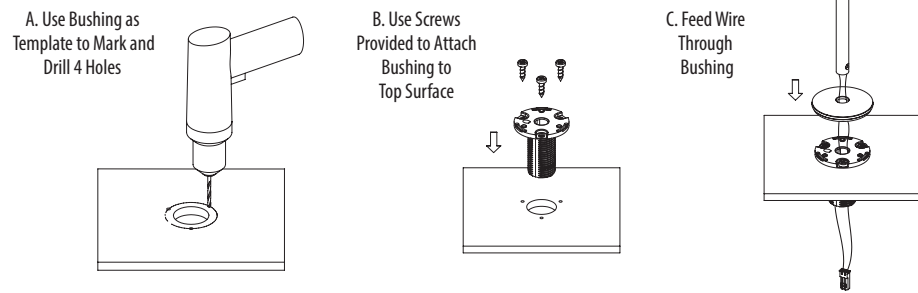

Combine **1R** and **2RL** fixtures with 8mm End Mount, T-Mount or Corner Mount Legs to create unlimited custom display configurations.

## SPECIAL MOUNTING OPTIONS - 16MM UPRIGHTS (2RL ONLY)

2RL fixtures can be configured with 16mm End Mount, T-Mount or Corner Mount Upright Legs to provide a continuous .63" [15.88mm] leg to match the diameter of the 2RL fixture. Upright Legs can be composed of empty or illuminated fixture segments.

(Fig. A) below details the dimensions to be considered when designing a basic two-legged fixture using 16mm Upright Legs. For more complex configurations that include T-Mount and Corner Mount Leg components, please visit the website and download the "16mm Free-Standing Display Worksheet" on the 2RL Downloads tab.

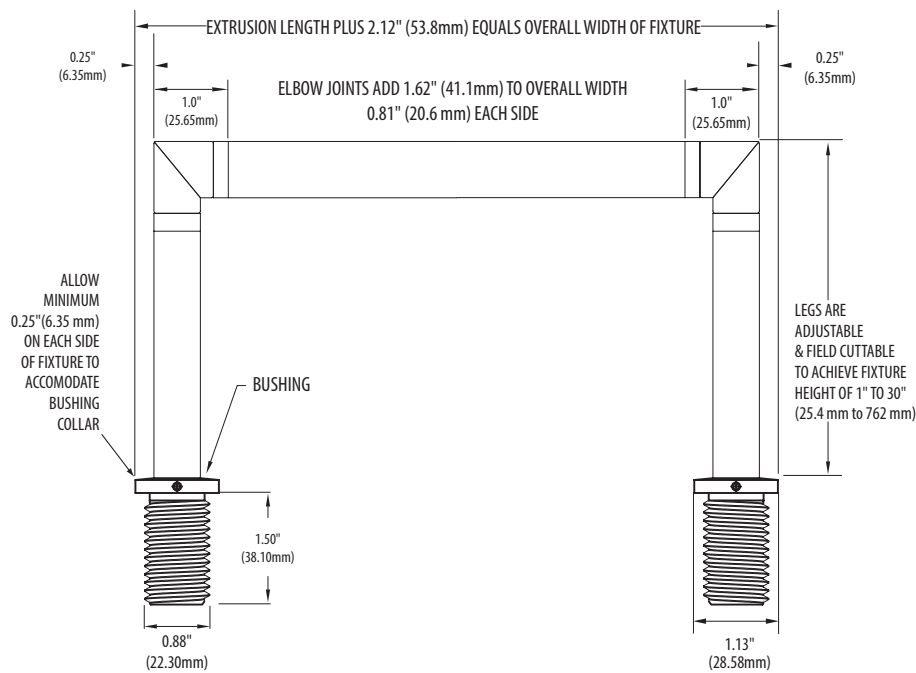

**Fig. A**  
Typical two-legged configuration

16mm legs can be configured using *empty extrusion* that matches the diameter and finish of the 2RL fixture, or can be configured using *illuminated segments* (contact VLT factory for more information); empty and illuminated legs are adjustable to achieve fixture height of 1" to 18"; *empty extrusion* is field cuttable

### Cutout Dimension for 16mm Bushing

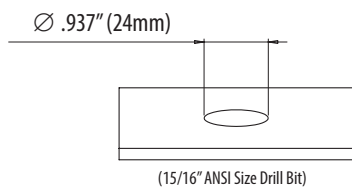

### Height Adjustment

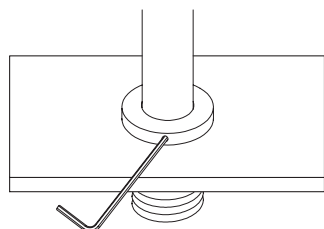

Use Allen Wrench and Set Screw in Bushing Collar to Adjust and Secure Height of 16mm Uprights



2RL fixture with 16mm illuminated legs.