

# LIGHT PANEL

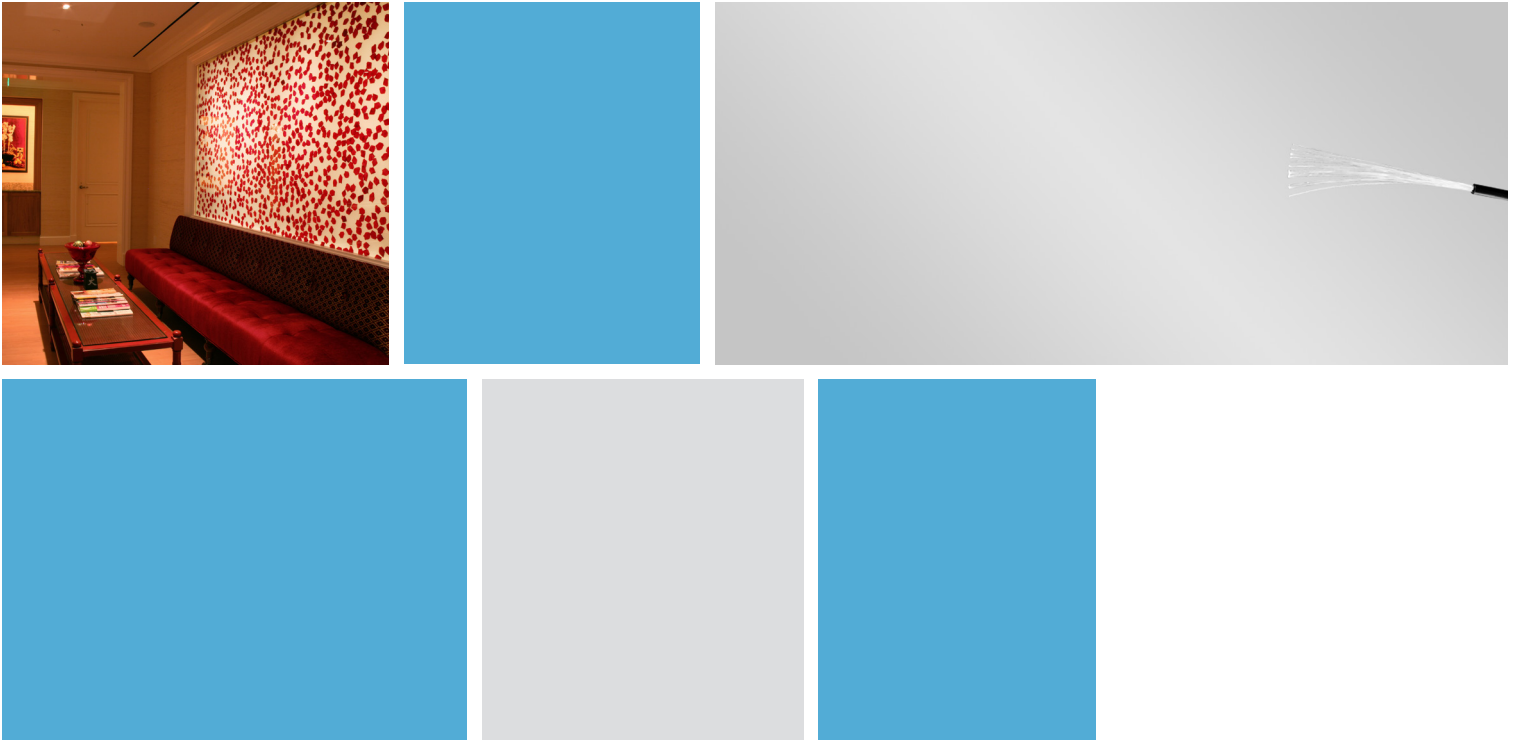

- Completely customized low-profile lighting
- Even backlighting for glass & onyx
- Zero maintenance at panel
- Stranded PMMA Fiber

# FIBER OPTIC LIGHTING

## Light Panel

Light Panel is a fully customizable lighting product that consists of an array of end-emitting fiber optic light points. Light Panel can be used in direct view applications, as in a sparkling backlight for a waterfall, but it is most often used to backlight materials such as frosted and stained glass, onyx, and other translucent materials. Because Light Panel's light points are fiber optic, most applications require no access to the Light Panel after installation – normal lamp maintenance is done at a remotely located illuminator. Combined with the chart below, the following pages will help you specify the appropriate Fiber Configuration and Array Spacing for your specific application.

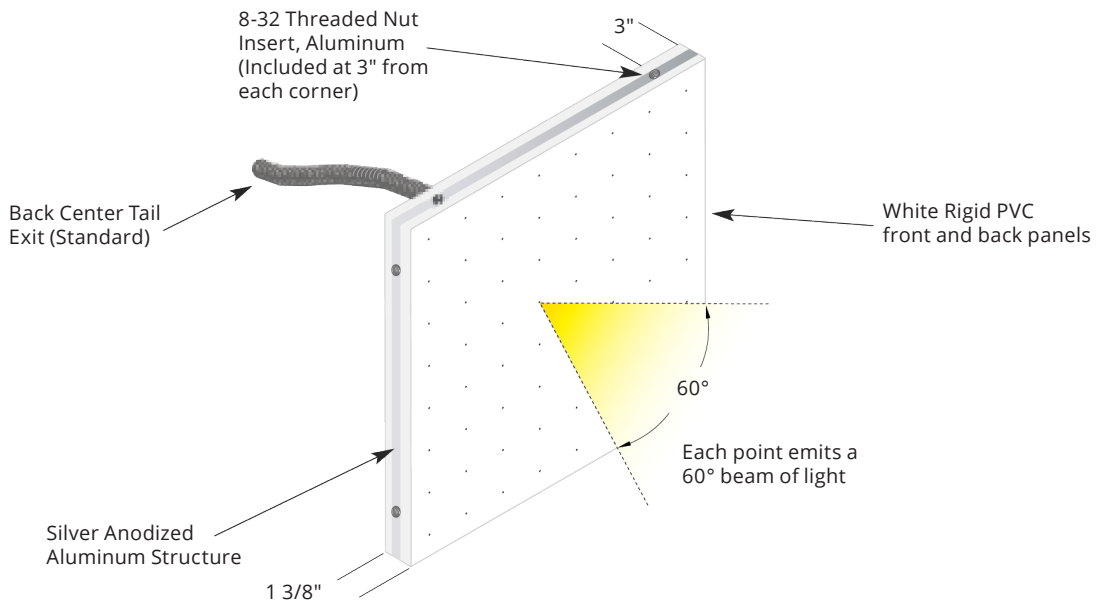
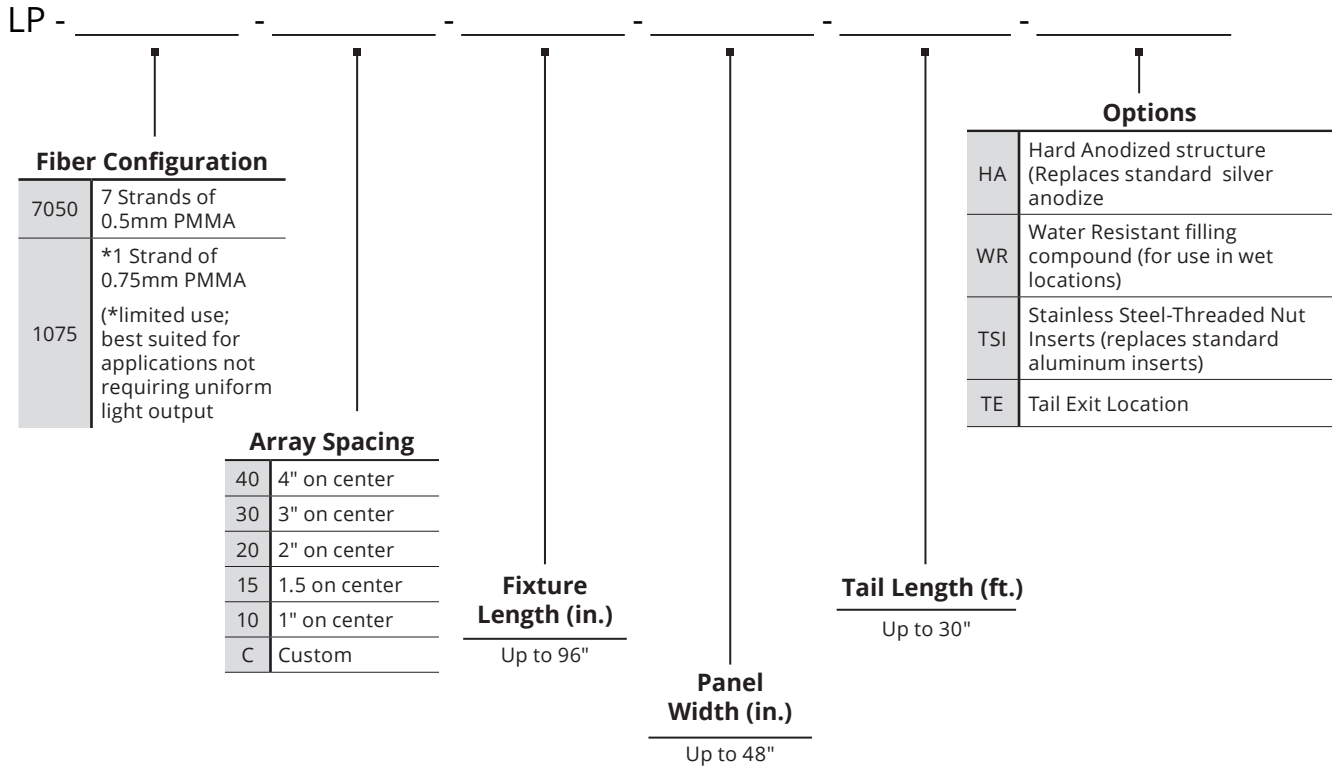

## Light Panel

---

### Fiber Configuration

Light Panel is offered with two standard Fiber Configurations. The 7050 configuration uses 7 strands of 0.50mm fiber for every light point. The 7 strands of fiber are randomized to produce virtually identical light output from each point - both in intensity and color temperature. When light points are identical they blend quickly - allowing the points to be spaced further apart than without randomization. Randomization also saves money; it makes the most efficient use of the illuminator's light output, so you can have more light points per illuminator.

In contrast, the 1075 configuration uses 1 strand of 0.75mm fiber in each light point. With just a single strand per light point, there is no ability to randomize. The resulting variations in intensity and color temperature cause the light to blend too slowly for the effective backlighting of solid materials. 1075 configurations are better suited for direct view applications, where the sparkle of tiny light points is a benefit.

### Array Spacing

Deciding the Array Spacing - how far apart the light points will be - is critical to the success of your application. When backlighting material with the 7050 configuration, your Array Spacing will be dictated by two factors: the type of material being lit, and the space available (the cavity) behind the material. Materials such as frosted glass are so even that the light points must be fully blended before they hit the glass. For this to happen, a ratio of 1:3 is typically needed, meaning that if the light points are spaced 1" apart, they will need 3" to fully blend. Other materials - such as onyx or stained

glass - have their own diffusing properties to help blend the light. For these materials, a ratio of 2:3 is typically appropriate - meaning that light points spaced 2" apart will be sufficiently blended in the same 3". Typically, 3" is the minimum "throw" distance possible, regardless of material type (in some cases, secondary diffusion materials may reduce the minimum throw distance).

### Intensity vs. Number Illuminators

Cavity depth and material type are the primary factors for determining Array Spacing, but other factors must also be considered. The closer the light points are spaced, the brighter the application will be. But with a maximum of 330 light points per illuminator (in a 7050 Fiber Configuration), the increased brightness may result in a more expensive, higher wattage application than desired. Each application must find a balance between desired brightness and number of illuminators required - and mockups are the best way to make this determination.

### Final Thoughts About 1075

The 1075 configuration is best when used in applications where the Array Spacing (and the resulting evenness of the light output) is a much more subjective decision. Again, an application must find a balance between the desired brightness and the number of illuminators needed, and although each illuminator can hold as many as 1,000 light points in this configuration, limiting the number to 500 or less will minimize the visible variations.

## Light Panel

### Cavity Requirements

On backlit applications, the Array Spacing determines the Throw Distance needed for the light points to blend, and that Throw Distance determines how much cavity space you'll need. Remember that the cavity behind the lit surface must accommodate BOTH the recommended Throw Distance PLUS the 1 3/8" depth of the Light panel itself. In most cases, 3" is the minimum Throw Distance possible. see the chart below for ratios and typical Array Spacing/Throw Distance combinations for 7050 Fiber configurations (1075 Fiber Configuration not recommended for backlit applications).

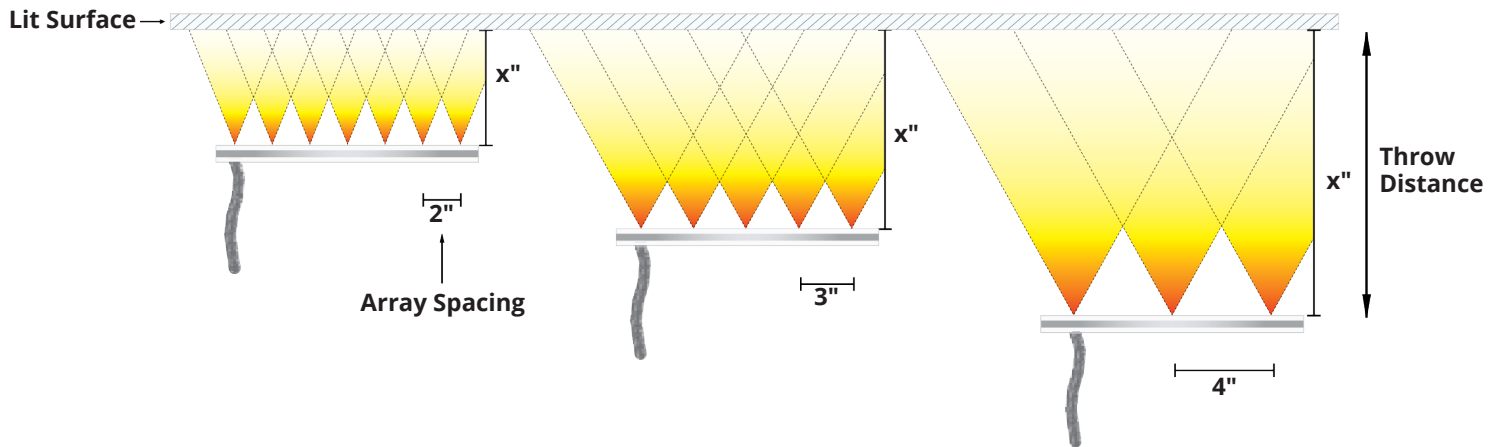

Throw Distance		
Array Spacing	Frosted Glass or Other Even Surface (1:3 Ratio)	Onyx or Other Mottled Surface (2:3 Ratio)
2"	6"	3"
3"	9"	4.5"
4"	12"	6"

Array Spacing determines the intensity of the light output from a piece of Light Panel (see chart below for footcandle measurements at 12"). If you are doing a backlit application, remember that light penetration will vary significantly depending on the material being backlit. A mock-up may be necessary to determine the best level of intensity for your project. The footcandle measurements below are based on 4 foot tail lengths and 42 watt illuminators filled to 100% capacity.

### Footcandles @ 12"

Array Spacing					
Fiber Configuration	1"	1.5"	2"	3"	4"
7050	720	308	180	80	44
1075	240	112	60	28	16

## Light Panel

### Illuminator Capacity

Array Spacing also determines how many illuminators your project will require. A single illuminator will provide up to 330 individual light points (in 7050 Fiber Configuration); the greater the Array Spacing, the greater the area that can be lit by a single illuminator. Based on Array Spacing, the chart below will tell you how many square feet can be lit with a single illuminator.

#### Max. Square Footage from Single Illuminator

Array Spacing					
Fiber Configuration	1"	1.5"	2"	3"	4"
7050	2.5 sq. ft.	5.25 sq. ft.	9.25 sq. ft.	21.5 sq. ft.	35 sq. ft.
1075	7.5 sq. ft.	16 sq. ft.	28 sq. ft.	61 sq. ft.	112 sq. ft.

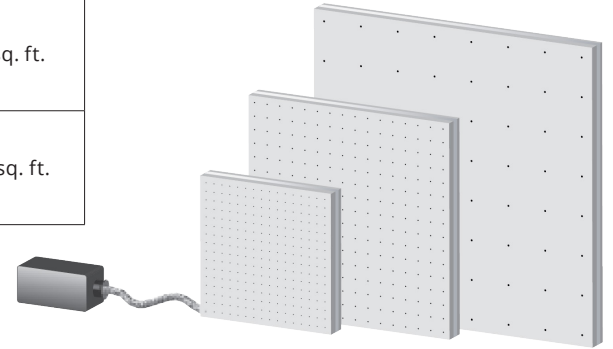

The Array Spacing determines how many square feet can be lit by a single illuminator

### Tail Exits

Though a Center Back exit is most common, Tail Exits can be located anywhere on the panel. Provide a sketch with your order to indicate a special exit location.

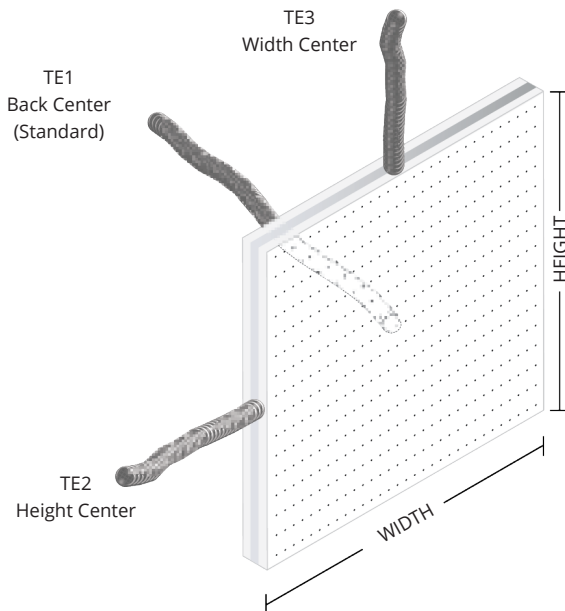

### Custom Shapes



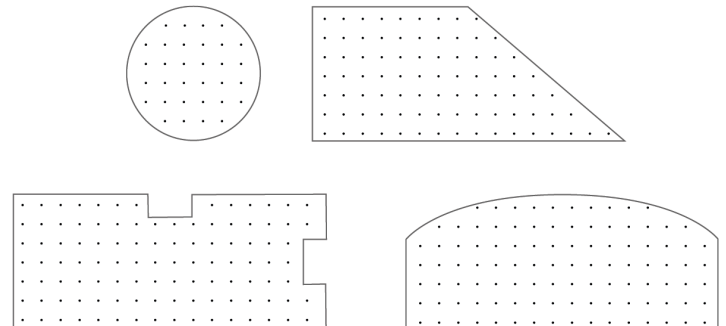



Light Panel shapes are not limited to squares and rectangles. We have manufactured all the shapes below and many more; just send us a sketch of the shape you need.



# FIBER OPTIC LIGHTING

## Light Channel

### Conduit Size Chart

CONDUIT DIAMETER	13.0mm	16.0mm	18.5mm	21.1mm	25.6mm	34.8mm
Diameter Shown to Scale						
Bend Radius	R = 1.5"	R = 1.75"	R = 2.0"	R = 2.25"	R = 2.5"	R = 3.5"
Max # of light points 7050	0 - 33	34 - 46	47 - 75	76 - 108	109 - 158	159 - 247
Max # of light points 1075	0 - 100	101 - 140	141 - 230	231 - 330	331 - 480	481 - 750

### Mounting Accessories

#### Specifications

CAT. NO. LP-AC-BR-

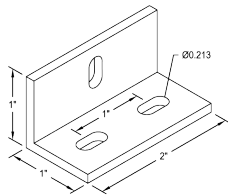

**Accessory:** Mounting Bracket  
**Primary Material:** Aluminum

**Description:**

Light Panel Mounting Bracket; Includes 8-32 screw for attachment to panel's threaded nut inserts.

**Finishes Available:**

Silver (AL), Hard Anodized (HA)

AL  
HA